

Pacmasta®

68 6DOL0 Carton 6DOHU

Pacmasta PMCS-

We have designed the Pacmasta Carton Sealing Machine for closing cartons DQ IRDP ERHV with OL0 the same height and width. It is an excellent choice for any low to high volume box closing needs of the industry DQ VWVFDWR08 WR PP KK DQ PP L0. Our PMCS- 686DOL0 Carton Machine can seal both VL0V of the carton simultaneously at a fast speed. The box to be sealed is driven by t0WRS belts D0R ERWWRHOWV through the machine, while rolling dispensers apply the pressure sensitive tape. After the sealed box is discharged, the machine is immediately ready for the next box.



Easy Operation
Push box & release



7LSOHMotor
(70WRS00R
ERWWRPdrive btes)



Robust Machine
Design Long working,
trouble-free life



Freely Movable on Caster
Wheels. Wherever your
packing work is done

Side Sealing Carton Sealer

Pacmasta PMCS-110

Pacmasta[®]

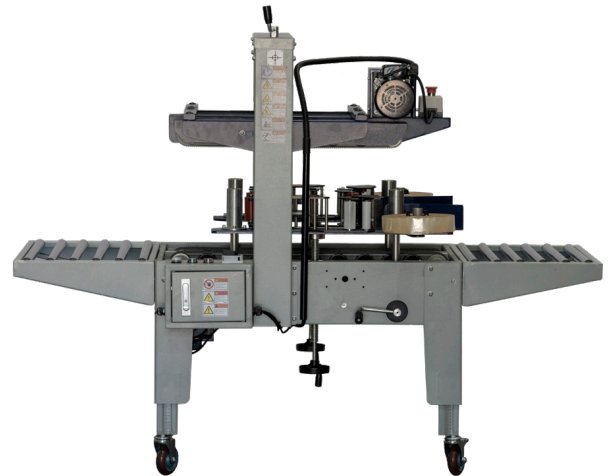

STANDARD FEATURES

- Fast side taping of all types/sizes of cartons/boxes (Height and width adjustable)
- Easy operation, just push box & release
- Triple motor with four drive belts, can push the heaviest of boxes
- Heavy-duty body with powder coated finish
- Robust machine design & long-working, trouble-free life.
- Freely movable on caster wheels, wherever your packing work is done
- Tape overlap length can be adjusted
- Blade guards, safe to work

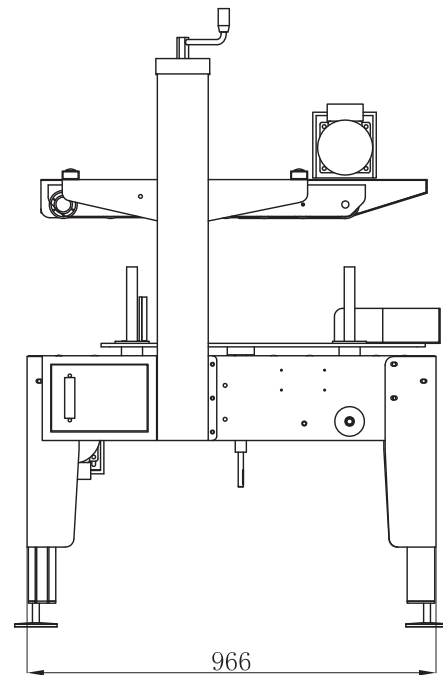

TECHNICAL DATA

DRIVE TYPE	Top and Bottom Belt Drive
POWER SUPPLY	220V/50Hz, 400W
CARTON SIZE	W(190-410mm) H(120-480mm) L (130mm-no limit)
TAPE SIZE	48-72mm x 1000M machine roll
SEALING SPEED	20 cartons/min
WORKTABLE HEIGHT	550-750mm
DIMENSIONS	L 960-1760mm x W 1078mm x H 1350-1550mm
GROSS WEIGHT	250kg

